

Endur E7

1200 x 800



Robust 3-runner plastic pallet for applications with high rotations

Made of impact-resistant PP – no metal reinforcements – this pallet is ideal for semi-hygienic applications and for high-rotation usage such as open or closed pools. The pallet deck is made using gas-assist technology, meaning that internal hollow channels make the pallet more rigid. This benefit is especially useful when the pallet is used in racks. Solid runners, double-walled recessed blocks and superb design make this pallet extremely robust and ensure a long service life.

Bottom support



> 3 runners (3R)



Available with various anti-slip options



Rounded perimeter border reduces risk of fork access damage.

Deck options



> open deck (OD)



> closed deck (CD)



Available with or without safety rim

Technical data*1

	Bottom support	Top deck	Dimensions [mm]	Load capacities*2 [kg]			Weight [kg]		Pallets per	
				Static	Dynamic	Racking	PP	PO	Stack	Truck
Endur E7 (OD-3R)	3 runners	open	1200 x 800 x 157	4000	2000	1000	18,0	-	15	495
Endur E7 (CD-3R)		closed								

Entry: 4 ways | Nesting height: - | Safety rim: 6 mm (optional without)

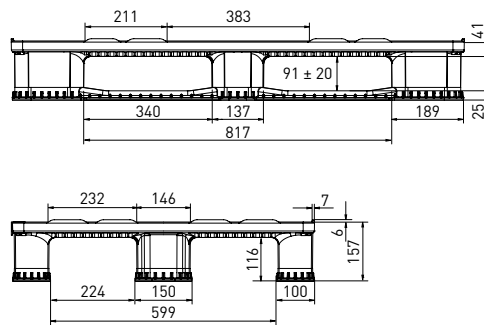
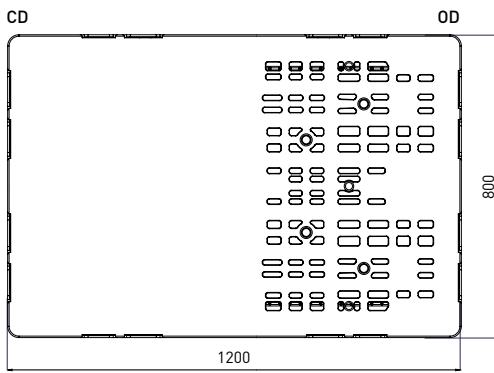

nominal sizes in mm

Options

- Color: (other colors on request*3) > Individual marking*3
- Anti-slip: safety rim, strips on deck, strips under blocks > RFID transponders
grommets on deck (OD), grommets under deck > Fire retardant
- ESD prevention: anti-static, conductive



*1 Figures can vary depending on the raw material used and options applied. *2 Guideline values are based both on experience and parts of test ISO 8611, which tests with evenly distributed loads at room temperature (20°C). Varying data may result from different conditions of usage. Your specific requirements can be identified upon request. *3 Minimum quantity required - PO pallets should only be used and stored in a dry environment. We reserve the right to change any of the stated information without prior notice.